

Ashalim, Israel

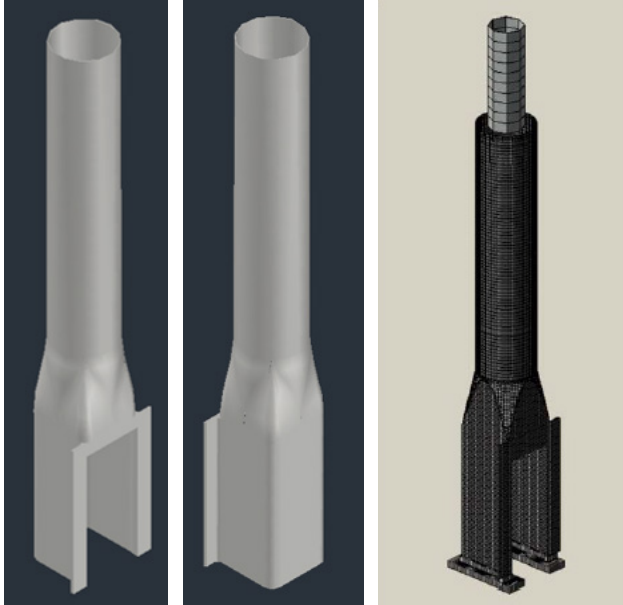

The Megalim Solar Thermal Power Station, located in Ashalim, in the "Ramat Negev" desert, is one of the largest projects of its type in the world. It is also the first solar thermal or concentrated solar power (CSP) plant in Israel.

This power station is made up of three plots, each with different solar technology, and should generate a total of around 310 MW energy need. Specifically, the Ashalim solar tower provides 121 MW of electricity. It is the largest renewable energy project in Israel and the 5th one in the world.

The project includes 50,600 computer-controlled heliostats with a surface area of over 20 m² and spread across an area of over 3 km². The heliostats track the sun in two axes and concentrate sunlight to a steam boiler on top of a tower generating high-temperature steam and high-pressure which is then piped to a turbine to produce electricity.

Key facts about the plant

- 121 MW Ashalim solar thermal power station
- Owner: Megalim Solar Power Ltd.
- Contractor: General Electric



Key facts about the tower

- Completed in 2017
- Solar tower
- Square cylinder to cylinder
- H 250m
- 36.4m x 26m
- Top outer Ø = 24.8m

The solar thermal energy systems generate power the same way as traditional power plants by creating high-temperature steam to turn a turbine. However, instead of using fossil fuels or nuclear power to create steam, Megalim uses the sun's energy.

General Electric acts as the main partner (EPC) with responsibility for the construction of the station, and BrightSource Energy as the responsible for the solar field and control system technologies.

In this power plant, FERBECK has been awarded an EPC contract related to the 250-meter-high solar tower by General Electric.



Solar tower

For the Ashalim solar tower, the concept of construction consists in using a concrete tower as an elevator shaft for the solar receiver, designed to be lifted in one piece from ground level.

From the practical point of view, solar receiver, vertical pipe rack and tower are built at the same time, in order to reduce the overall project schedule.

FERBECK's scope of work includes:

- foundation
- concrete tower
- wind spoilers
- shifting and heavy lifting of solar receiver
- solar receiver supporting platform
- walkways
- access lift
- electric system (lighting, inner power supply, aircraft signalization lamps...)
- lightning protection system

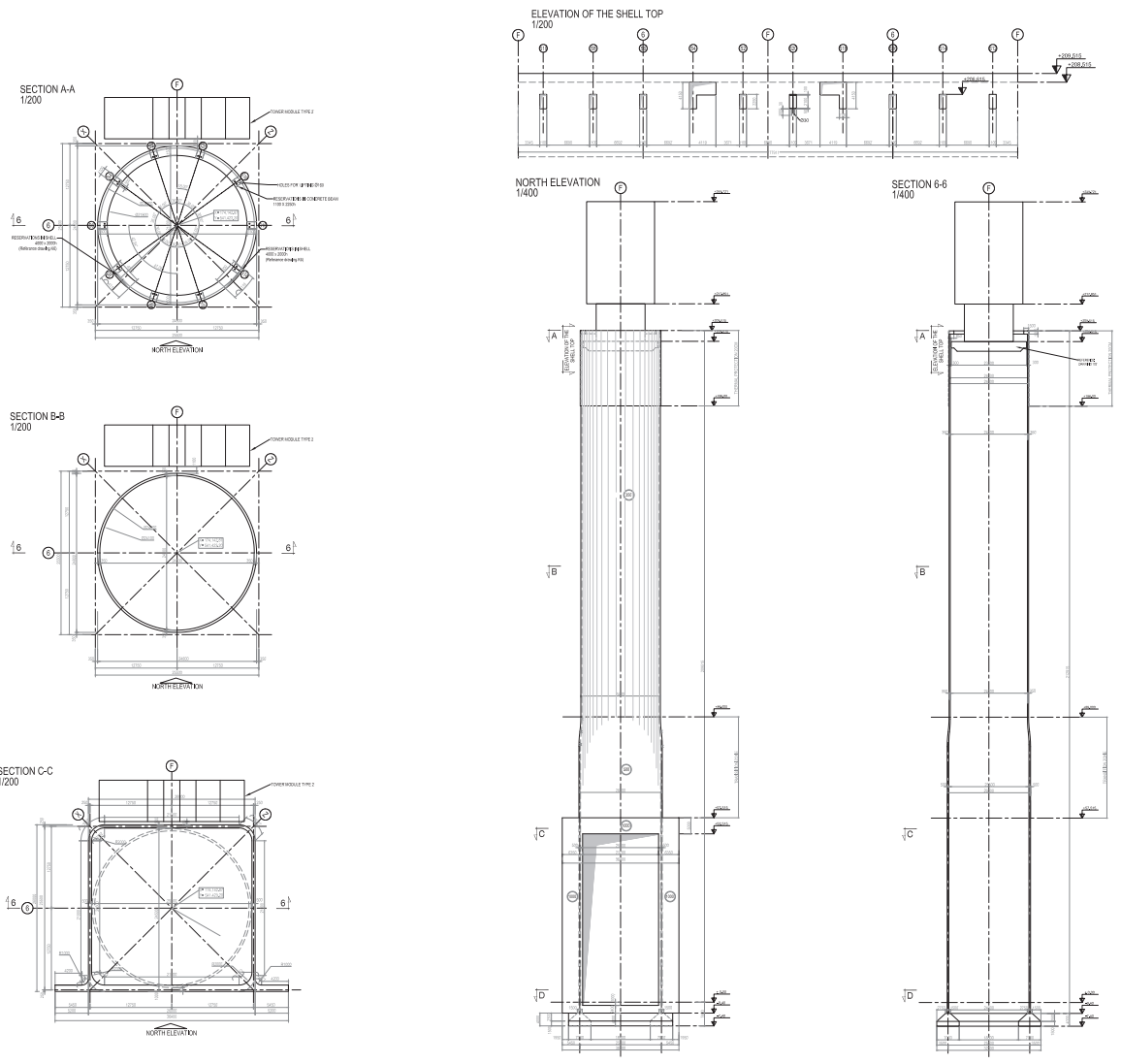



Foundation

The northern foundation beam below the enormous opening is prestressed using cables to close the portico and give it rigidity.

It is made of 2,250m³ of concrete with the following size:

- 32.5m x 32.25m
- h 4m at EL.-7.4m

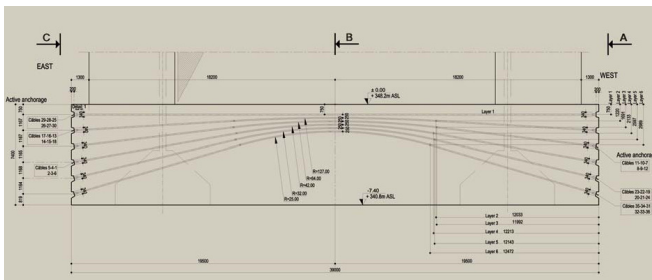

Six beds of 19T15S parabolic cables

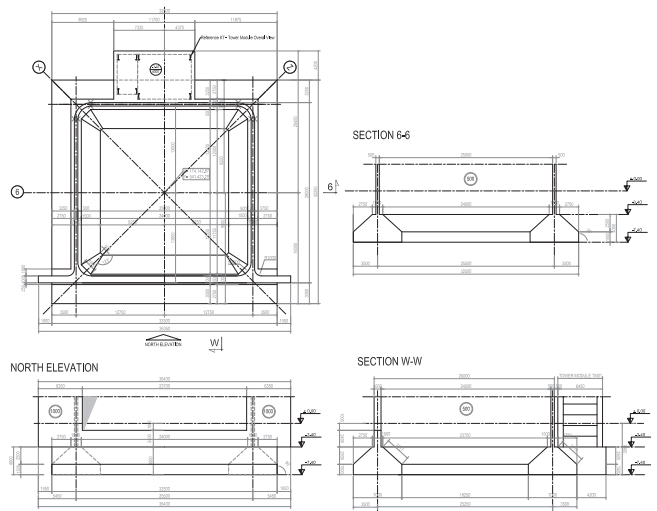

Plan of the foundation



The north portion of the solar tower





Concrete tower

The reinforced concrete tower is 210m high. Its main functional requirement is to support weight to raise and bring the solar receiver to the top through an opening of 24mx52m.

In the preliminary design phase, several tower geometries were compared to accommodate this opening, and finally a mixed geometry was chosen to better reduce wind loads and lateral deformations: it consists of a square section (from 0 to 57m) with a portico around the opening, and a circular section (from 89 to 210m) connected by a transition zone.

Using a tailor-made sliding formwork is the best choice for building this kind of structure, not only for the shortest construction schedule but also for its extremely complex geometry that sees changes in the thickness of the walls (50 cm at the ground, 35 cm at the top, 120 cm around the opening).

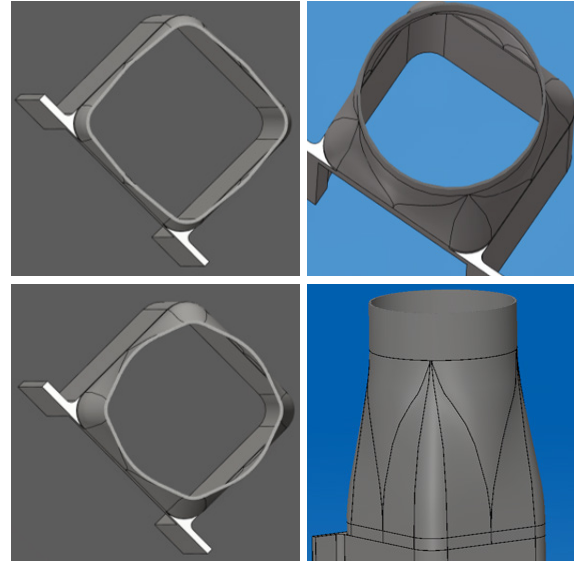

Transition zone

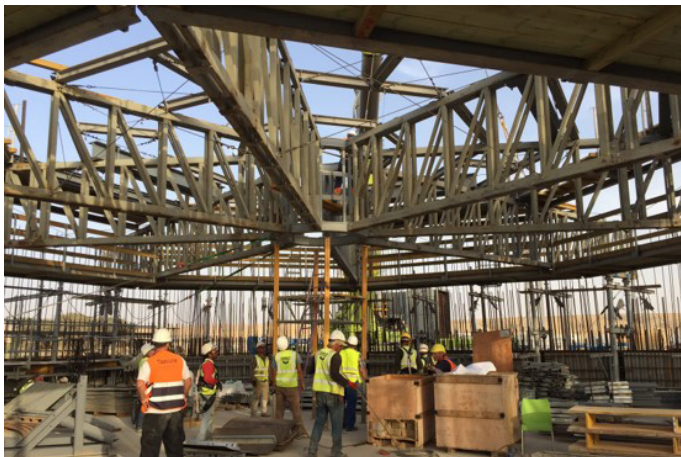



| Wind spoilers

A wind tunnel test is carried out to test the wind actions on the tower. In the absence of a vibration damper, a final design with the application of 72 helical pattern wind spoilers over the first 75m of the tower is performed.

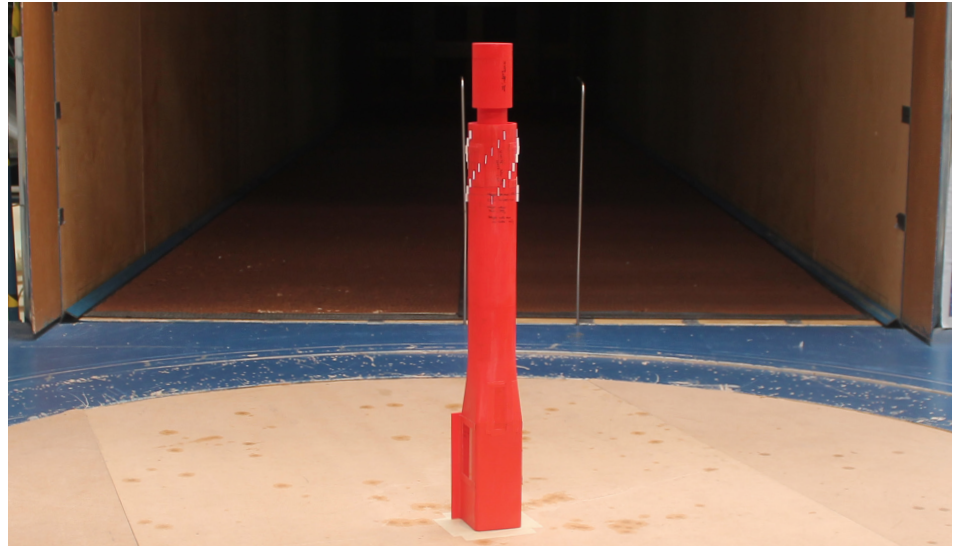
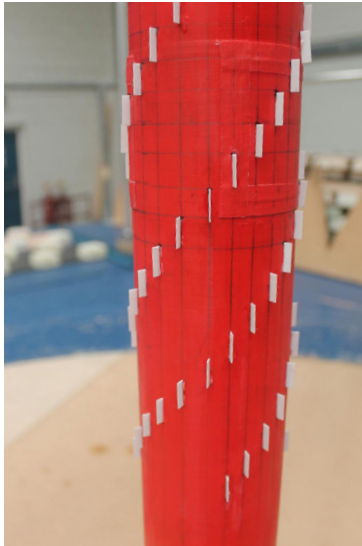

Wind tunnel test

| Solar receiver

The solar receiver, or so-called boiler, measures 21.2m in diameter and 50m in height. It is assembled and tested on site, and shifted inside the tower with its supporting grid to be finally lifted and anchored in their functional position at the top.

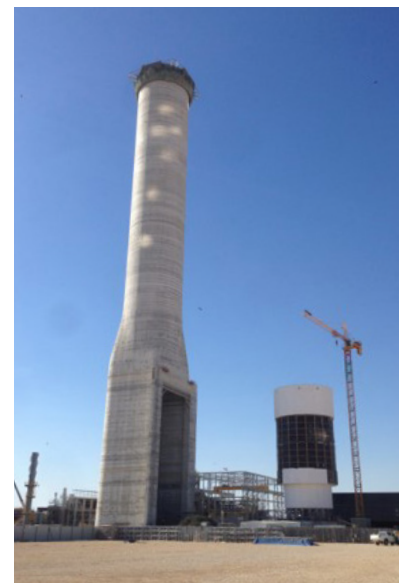



Solar receiver

Shifting

The solar receiver is directly assembled on the supporting grid while the equipment such as pumps, rails and pads on the transition slab are prepared. The 3000t structure is finally pushed inside the tower using the railways of the transition slab and connected with lifting cables.

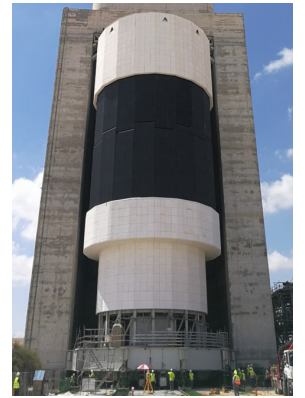
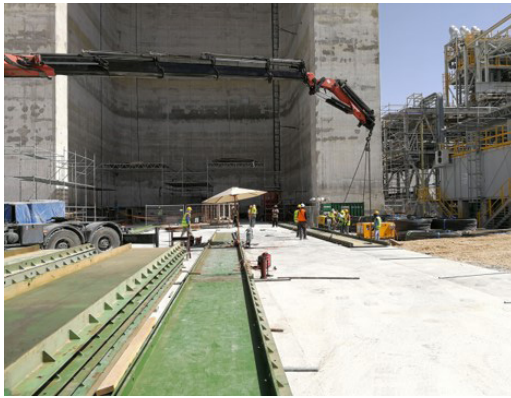

Heavy lifting

The lifting cables are inserted into the grid passage tubes and the assembly of the end anchors are carried out, the boiler is taken over by the cable jacks and starts its rise to reach 250m. Once at top, the grid is connected with bolts to its extensions. The lifting is completed.

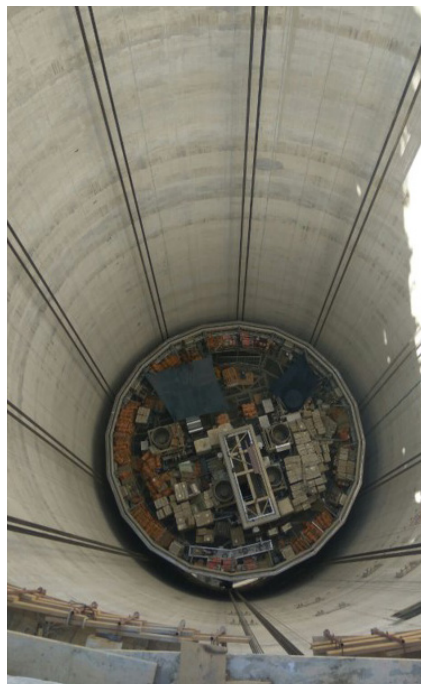

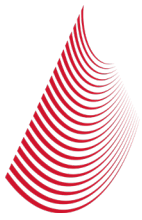

Overview of the plant

